

Description

PECJ N-channel MOSFET

Features

- 30V,90A
 $R_{DS(ON)} < 5m\Omega @ V_{GS} = 10V$
 $R_{DS(ON)} < 10m\Omega @ V_{GS} = 4.5V$
- Advanced Trench Technology
- Excellent $R_{DS(ON)}$ and Low Gate Charge
- Lead free product is acquired

Application

- Load Switch
- PWM Application
- Power management



100% UIS TESTED!
100% ΔVds TESTED!

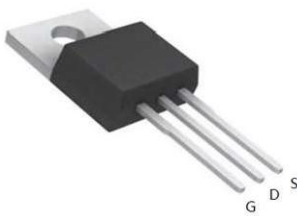

TO-220C top view

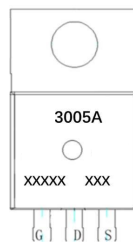

Marking and pin Assignment

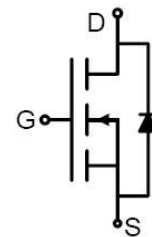

Schematic Diagram

Package Marking and Ordering Information

Device Marking	Device	OUTLINE	Device Package	TUBE (PCS)	Inner Box (PCS)	Per Carton (PCS)
PECJ3005A	PECJ3005A	TUBE	TO-220C	50	1,000	5,000

Absolute Maximum Ratings ($T_C = 25^\circ\text{C}$ unless otherwise specified)

Symbol	Parameter	Max.	Units
V_{DSS}	Drain-Source Voltage	30	V
V_{GSS}	Gate-Source Voltage	± 20	V
I_D	Continuous Drain Current	$T_C = 25^\circ\text{C}$	90
		$T_C = 100^\circ\text{C}$	58
I_{DM}	Pulsed Drain Current ^{note1}	360	A
E_{AS}	Single Pulsed Avalanche Energy ^{note2}	90	mJ
P_D	Power Dissipation	$T_C = 25^\circ\text{C}$	90
$R_{\theta JC}$	Thermal Resistance, Junction to Case	1.67	$^\circ\text{C}/\text{W}$
T_J, T_{STG}	Operating and Storage Temperature Range	-55 to +175	$^\circ\text{C}$

Electrical Characteristics (T_J=25°C unless otherwise specified)

Symbol	Parameter	Test Condition	Min.	Typ.	Max.	Units
Off Characteristic						
V _{(BR)DSS}	Drain-Source Breakdown Voltage	V _{GS} =0V, I _D =250μA	30	-	-	V
I _{DSS}	Zero Gate Voltage Drain Current	V _{DS} =30V, V _{GS} = 0V,	-	-	1.0	μA
I _{GSS}	Gate to Body Leakage Current	V _{DS} =0V, V _{GS} = ±20V	-	-	±100	nA
On Characteristics						
V _{GS(th)}	Gate Threshold Voltage	V _{DS} = V _{GS} , I _D =250μA	1.0	1.5	2.5	V
R _{DS(on)}	Static Drain-Source on-Resistance <small>note3</small>	V _{GS} =10V, I _D =30A	-	3.8	5	mΩ
		V _{GS} =4.5V, I _D =20A	-	7	10	
Dynamic Characteristics						
C _{iss}	Input Capacitance	V _{DS} =15V, V _{GS} =0V, f = 1.0MHz	-	1950	-	pF
C _{oss}	Output Capacitance		-	320	-	pF
C _{rss}	Reverse Transfer Capacitance		-	240	-	pF
Q _g	Total Gate Charge	V _{DS} =15V, I _D =20A, V _{GS} =10V	-	42	-	nC
Q _{gs}	Gate-Source Charge		-	4	-	nC
Q _{gd}	Gate-Drain("Miller") Charge		-	14	-	nC
Switching Characteristics						
t _{d(on)}	Turn-on Delay Time	V _{DS} =15V, R _f =0.75Ω, R _{GEN} =3Ω, V _{GS} =10V	-	13	-	ns
t _r	Turn-on Rise Time		-	36	-	ns
t _{d(off)}	Turn-off Delay Time		-	43	-	ns
t _f	Turn-off Fall Time		-	16	-	ns
Drain-Source Diode Characteristics and Maximum Ratings						
I _S	Maximum Continuous Drain to Source Diode Forward Current		-	-	90	A
I _{SM}	Maximum Pulsed Drain to Source Diode Forward Current		-	-	360	A
V _{SD}	Drain to Source Diode Forward Voltage	V _{GS} = 0V, I _S =30A	-	-	1.2	V
t _{rr}	Body Diode Reverse Recovery Time	I _F =20A, di/dt=100A/μs	-	16	-	ns
Q _{rr}	Body Diode Reverse Recovery Charge		-	5	-	nC

Notes:1. Repetitive Rating: Pulse Width Limited by Maximum Junction Temperature

2. EAS condition: T_J=25°C, V_{DD}=30V, V_G=10V, L=0.5mH, R_G=25Ω, I_{AS}=19A

3. Pulse Test: Pulse Width≤300μs, Duty Cycle≤0.5%

Typical Performance Characteristics

Figure 1: Output Characteristics

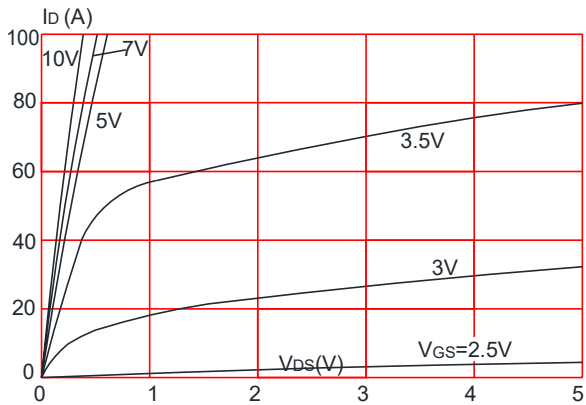

Figure 2: Typical Transfer Characteristics

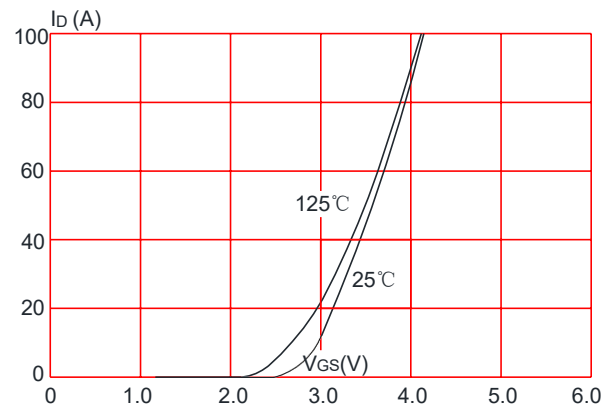

Figure 3: On-resistance vs. Drain Current

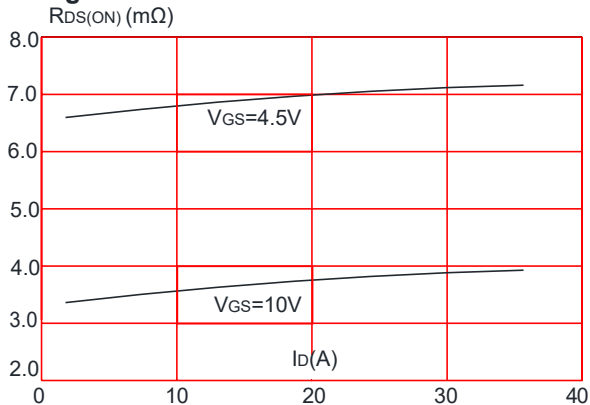

Figure 4: Body Diode Characteristics

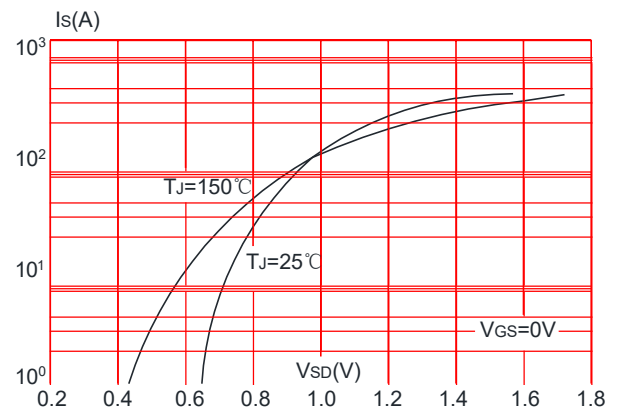

Figure 5: Gate Charge Characteristics

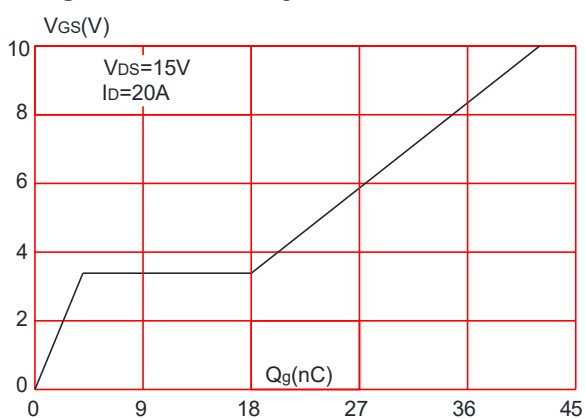

Figure 6: Capacitance Characteristics

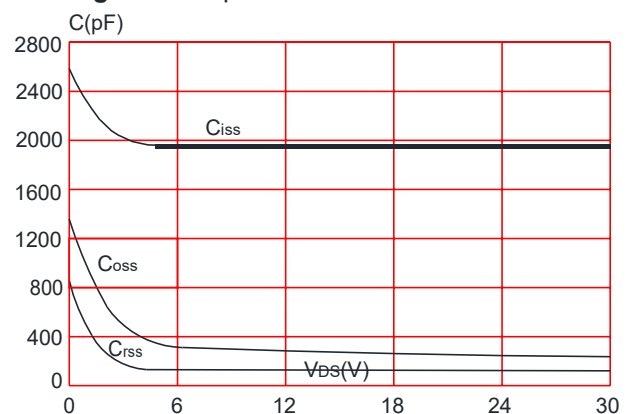

Figure 7: Normalized Breakdown Voltage vs. Junction Temperature

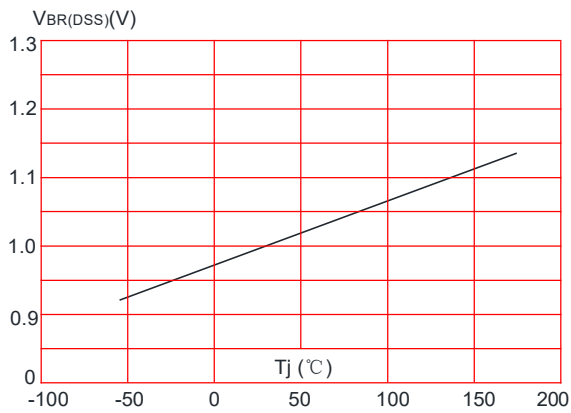

Figure 8: Normalized on Resistance vs. Junction Temperature

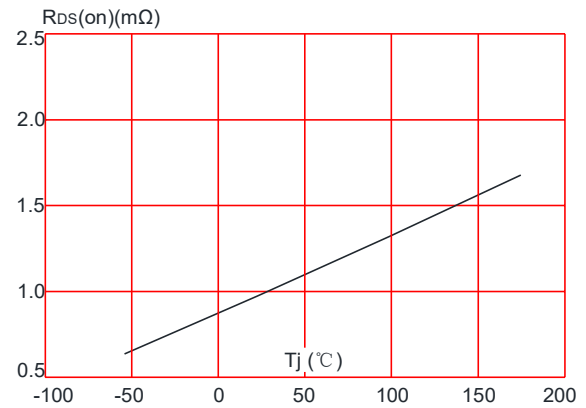

Figure 9: Maximum Safe Operating Area

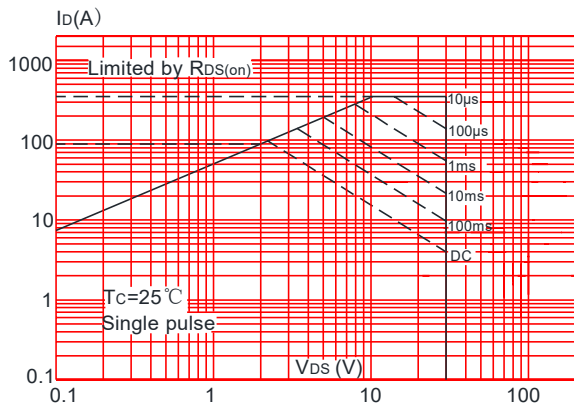

Figure 10: Maximum Continuous Drain Current vs. Case Temperature

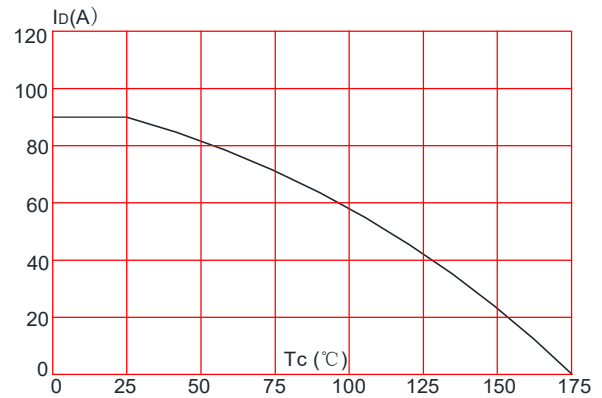
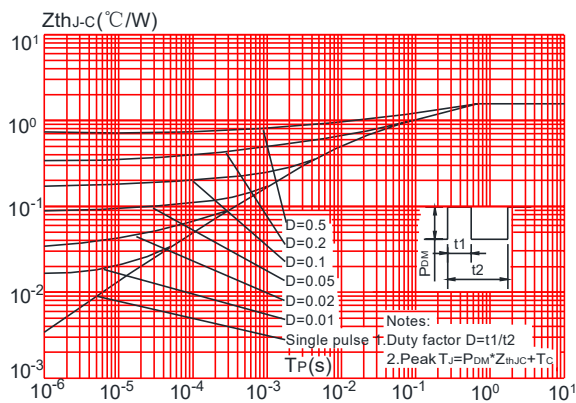

Figure.11: Maximum Effective Transient Thermal Impedance, Junction-to-Case



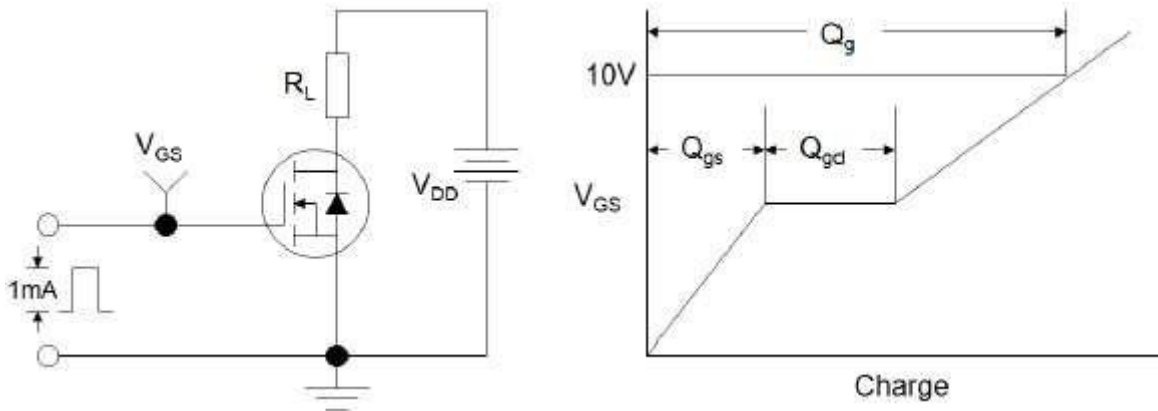

Figure1:Gate Charge Test Circuit & Waveform

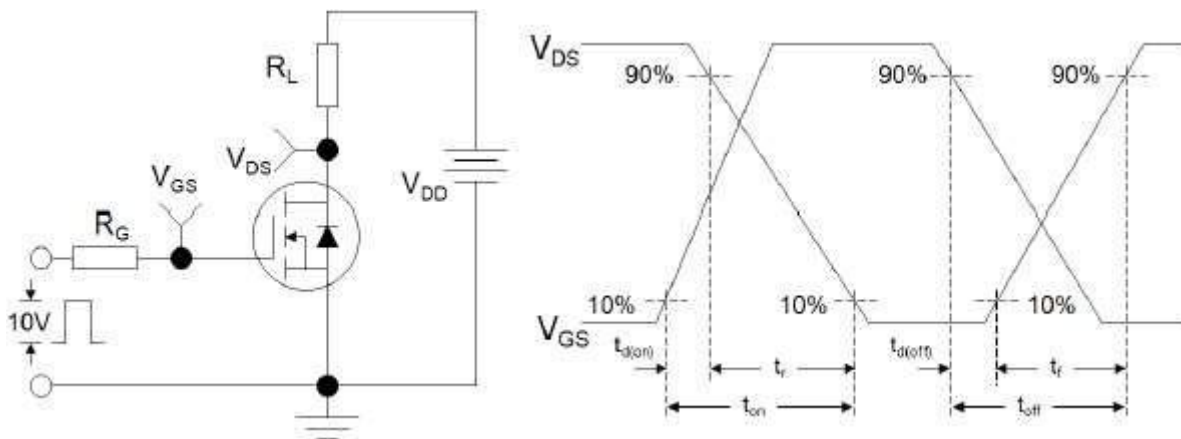

Figure 2: Resistive Switching Test Circuit & Waveforms

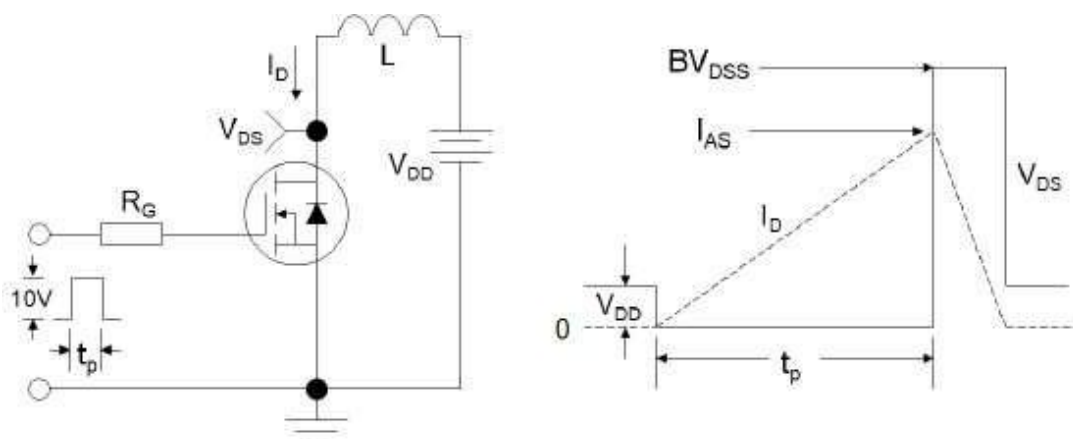
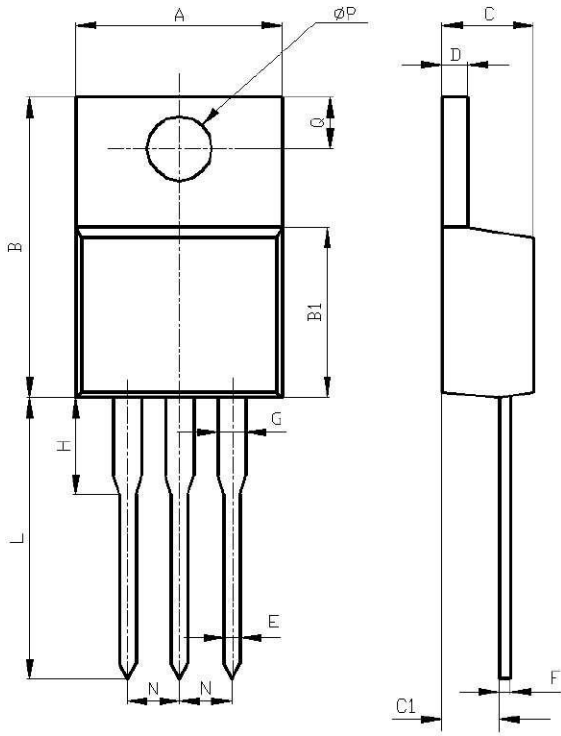

Figure 3:Unclamped Inductive Switching Test Circuit & Waveforms

Package Mechanical Data-TO-220C



单位: mm

项目	规范(mm)	
	MIN	MAX
A	10.1	10.5
B	15.2	15.6
B1	9.00	9.40
C	4.40	4.60
C1	2.40	3.00
D	1.20	1.40
E	0.70	0.90
F	0.40	0.60
G	1.17	1.37
H	3.30	3.80
L	13.1	13.7
N	2.34	2.74
Q	2.40	3.00
ϕP	3.70	3.90